

TELESCOPIC HANDLERS

AGRICULTURE



HIGH LEVEL PERFORMANCE GUARANTEED OVER TIME

Since its inception, Faresin has had the construction sector as its core business. This peculiarity, perhaps unique among telehandler manufacturers, has had as a direct consequence the development and finalizing of highly reliable machines and, above all, with high performance. Furthermore, to meet the needs of the construction sector, the company has planned to create customized machines with specific functions: bucket mode, constant flow, creep mode. These are just some examples of the possibilities offered by Faresin machines to their customers.





FS COMPACT

7.32C | 9.32C

(3,2 ton | 7-9 m)

CLASSIC 55 | CLASSIC 75 | DYNAMIC 85
PERFORMANCE 85 | EXCELLENCE 85



FS MIDDLE

7.35 | 7.45 | 8.40 | 10.40

(3,5-4,5 ton | 7-10 m)

CLASSIC 55 | CLASSIC 75 | DYNAMIC 85
PERFORMANCE 85 | EXCELLENCE 85 |
EXCELLENCE VARIO 100



FULL ELECTRIC

6.26 | 14.42 | 17.40 | 17.45

(2,6-4,5 ton | 6-17 m)



SMALL RANGE

6.26

(2,6 ton | 6 m)

CLASSIC 52



BIG RANGE

14.42 | 17.40 | 17.45

(4-4,5 ton | 14-17 m)

CLASSIC 55 | CLASSIC 74



HEAVY DUTY RANGE

9.60 | 9.70 | 10.65

(6-7 ton | 9-10 m)

CLASSIC 74 | HLS 74

TELESCOPIC HANDLERS

- FS TELESCOPIC HANDLER** **4**
 - ADVANCED DESIGN 4
 - 360° VISIBILITY 6
 - PERFORMANCE FIRST 10
 - DEDICATED TRANSMISSIONS 12
 - HYDRAULIC POWER 13
- FULL ELECTRIC** **14**
 - SUSTAINABLE FORCE 15
 - FULL ELECTRIC RANGE 16
 - QUEEN CAB: COMFORT, VISIBILITY AND ERGONOMICS 17
- TELESCOPIC HANDLER** **18**
 - QUEEN CAB: COMFORT, VISIBILITY AND ERGONOMICS 18
 - STAGE V ENGINES: POWER AND RELIABILITY 20
 - TRANSMISSIONS: FULL CONTROL AND RELIABILITY 21
 - INTELLIGENT HYDRAULICS 22
 - EXTRAORDINARY STRENGTH 22
 - LIFTING HEIGHTS FOR EACH NEED 23
- DATA SHEET** **24**
- ACCESSORIES** **40**
- FARMATICS** **42**
- AFTERSALES** **43**

FS SERIE

THE NEXT GENERATION

The FS Series marks the entrance of the entire range of Faresin telehandlers to the future through an industrial project built on 40 years of experience in the market. Industrialising efficiency: this was the choice made by Faresin Industries with a Compact that sits at the top of its category, which was developed ready to welcome future developments in technology.

FUNCTIONAL LINES

The tapering of the hood towards the front right wheel leaves a complete, unobstructed view of any obstacles on the ground, significantly improving safety.

PRECISE AND SMOOTH CONTROL OF EXTENSION OPERATIONS AND ACCESSORIES

SPACIOUS CAB WITH INCREASED 360° VISIBILITY

ERGONOMIC CONTROLS AND COMFORT

VISIBILITY & DESIGN

TOTAL CONTROL

ADVANCED DESIGN

The new design combines emotion, style and technical features in every detail. The clean and essential lines are the result of experience acquired across all sectors from thousands of clients, and the meticulous work of our engineers and designers. The result is exceptional visibility for the driver.

TELEHANDLERS NEXT GENERATION



FULL LED LIGHTS

Headlamps with high visibility LED lights, whether for work or driving, to provide all the necessary lighting for travel by road and for night works. On request, additional work lighting solutions can be applied to further increase the lighted area.

SOLID CURVES

Mudguards featuring an original design made from a high-resistance material, giving the machine distinctive character while also efficiently fulfilling their protective function. The large rear-view mirrors are folding to facilitate access in tight spaces. By reaching just over two metres of maximum height in the FS LC version, this telehandler shows all of its flexibility.



360° VISIBILITY

A new concept of an ergonomic cab where every detail is inserted in the most comfortable position for the operator. The Faresin cab is designed to maximise operator well-being and offer a truly unique work experience. An ultra-technological dashboard with intuitively arranged controls, grouped in accordance with a functional logic. With regard to safety, the Rops and Fops European certification and Ansi certification for the United States are perfectly valid, in strict compliance with current legislation.

**IMMEDIATE CONTROL
OF ALL OPERATING AND
SAFETY PARRAMETERS**

**HIGHLY SENSITIVE
AND ACCURATE BOOM
CONTROLS AND MOVEMENT
MANAGEMENT**

**SETTING &
PROGRAMMING OF
ADVANCED MACHINE
MANAGEMENT
FUNCTIONS**

**ORGANISER
TRAY WITH
USB**

**AIR SUSPENSION SEAT WITH
MULTI-REGULATION TO
REDUCE FATIGUE**

FS DISPLAY

The operator must always have all operating parameters within view and under control: the large 7-inch touchscreen display shows the engine operating parameters and safety parameters, and also integrates the controls of the bluetooth radio and new automatic A/C system, as well as the work light controls and much more.



INTEGRATED
ANTI-ROLL

TOUCHSCREEN
CONTROLS

FS JOYSTICK

Both comfort and safety, the joystick is now incorporated into the armrest of the seat. It moves in conjunction with the seat's air suspension and allows safe and constant control of the boom functions, even in difficult working conditions. This ergonomic choice significantly increases control precision and driving comfort. The reverse gear can also be controlled from here. Supplied standard in Excellence version.



The attention to detail of the safety aspects and control of commands leaves no room for uncertainty. The controls stand out on the interior colour scheme and are always readily identifiable. The backlit keypad, which contains the less frequently used controls and the safety key or side tilt indicator, are always instantly visible.

The FS Selector provides access to the control and setting parameters of the display without needing to take your hand off the armrest. It also incorporates the steering method controls.





EFFICIENT VENTILATION

Heating or cooling regulation in the cab has been further improved with the adoption of seven adjustable vents located in critical points, and by increasing the air flow power, thus rapidly eliminating any accumulated condensate.



PRECISE STEERING

Simple driving is synonymous with the broadest possible use of the telehandler by expert and less experienced people. The ergonomic driving position combined with the versatility of use make FS a simple, yet all-purpose public works vehicle.



COURTESY STEP

Getting into the cab is much easier thanks to the innovative foot support lit up with a LED courtesy light, making it safe to get in and out of the cab in all conditions. A non-slip step and safety handles help the operator climb up with total ease.

DOCILE POWER

Loading, backing up, raising the boom, unloading, then starting again and repeating the same work cycle, is now simple thanks to the movement direction control inserted in the FS Joystick. One hand to control power and agility.





MORE MANEOUVRING SPACE

Explaining agility means considering multiple aspects. The turning radius of just 3.8 metres is enhanced by the almost total absence of any rear overhang. In practical terms, this translates into improved manoeuvrability in tight spaces.



THRUST & TRACTION

Pushing power is just as important as the machine's stability when raising the boom. These characteristics are easily satisfied by the FS thanks to its long pitch and weight distribution on the frame. Loading manure and grain are two critical moments which are not feared by this machine.

SAFE LOADS

The inching function reduces the speed during the approach, making boom movements safer and more precise, improving performance and safety.



PERFORMANCE FIRST

Designing with a view to the future also means striving to reduce environmental impacts, minimise fuel consumption, optimise the use of resources, and ultimately improve performance. Many of these improvements are not physically visible, but the innovative shape of the engine hood is clear. It is designed to facilitate the intake of a copious flow of fresh and clean air, intelligently directed into the engine compartment, keeping all parts at the ideal temperature.



The longitudinal layout of the Diesel engine and connected components allow improved power transmission and efficient management of the cooling system. The integrated exchanger, positioned horizontally far from sludge and dirt, integrates an electronically controlled ventilation system that only works when needed, and which can invert the air flow to expel the accumulation of any crushed leaf dust.

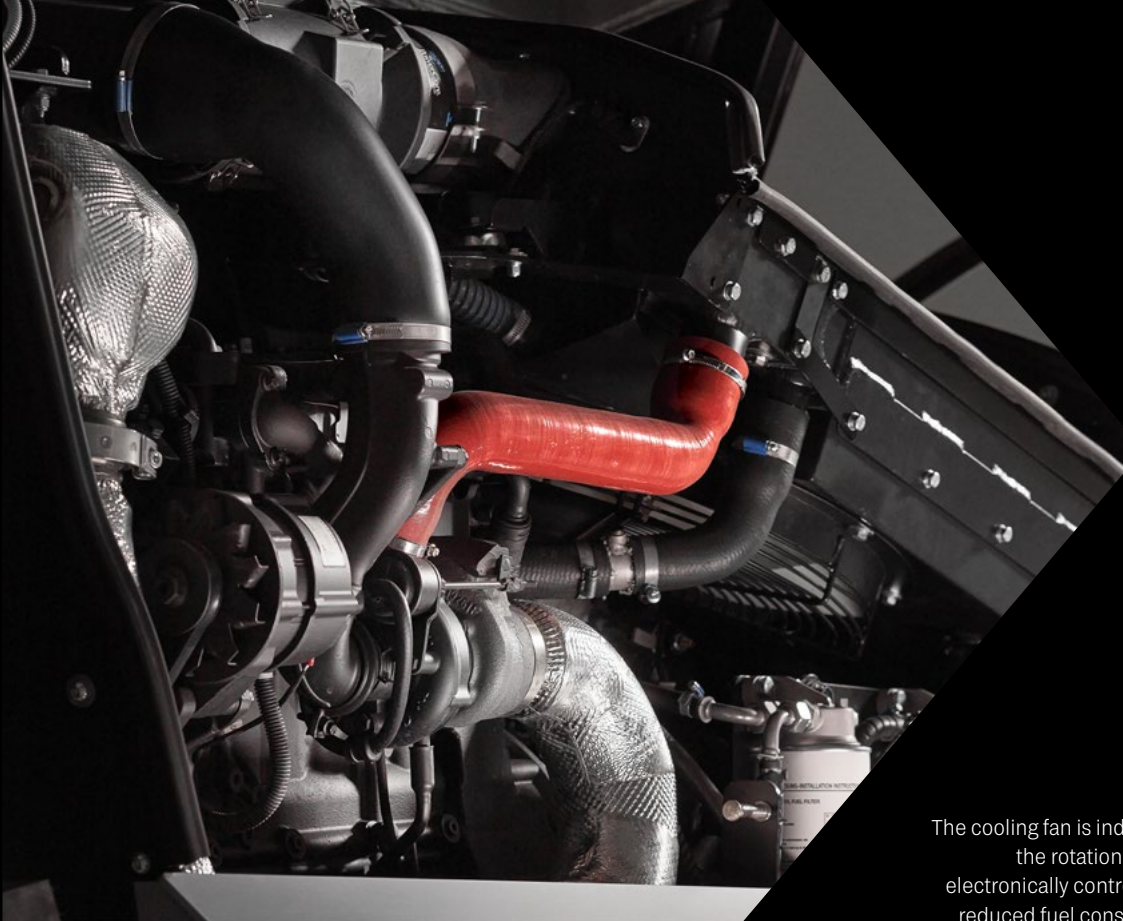

A WORK PARTNER

Thanks to the new engines, the maintenance periods have been extended and now reach up to 1,000 hours for certain components, translating into a significant reduction in the cost of consumables and time. Along with reduced fuel consumption – which for these engines is always less than 215 g/kW/h – and silent operation, these are all characteristics making FS Compact an economical and reliable workmate.



HIGHER PERFORMANCE LESS FUEL CONSUMPTION

There are 5 available engines, all 4-cylinder, and all Stage V compliant, common rail, with turbo compressor and intercooler with specific power distribution curves for these machines. High performance even at low speed to respond to the need for power associated with specific uses. High torques optimised for high performance and low fuel consumption.

SMART FAN

The cooling fan is independently activated and automatically self-regulates the rotation speed depending on the temperature. Reversible and electronically controlled, it combines perfect temperature regulation with reduced fuel consumption, representing a conclusive solution for use in dusty environments.

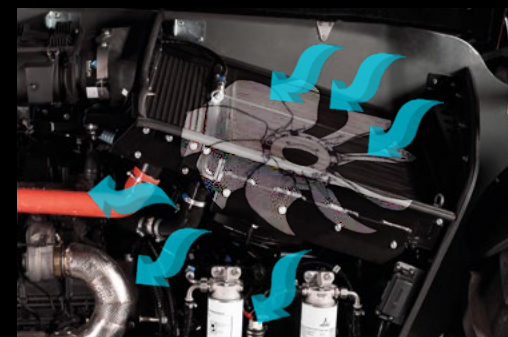

ADVANCED CONTROL

The original “Power on demand” software is exclusive to Faresin Industries and has allowed the introduction of various automatic safety functions including the “AutoStop”, which shuts down the engine when the operator gets up from the seat, and then turns on again – automatically – when he/she returns. Solutions which not only protect the operator, but also save on fuel.



DEDICATED TRANSMISSIONS

All versions of the FS are supplied standard with Ecodrive hydrostatic transmission control, an advanced solution able to dose the distributed power depending on the driving mode in order to best exploit the engine power while simultaneously and substantially reducing fuel consumption. Two transmissions are used to satisfy operating needs: a single gear hydrostatic transmission from 0 to 30 km/h with high performance thanks to the elasticity of the powertrain. A hydrostatic transmission with two-speed gearbox for greater traction thrust, which reaches 40 km/hour and when travelling by road.



FOUR WHEELS ALWAYS IN TRACTION

The hydrostatic transmission constantly offloads the power on all four wheels of the telehandler, always guaranteeing traction and stability. The long pitch of the Faresin Industries Compact telehandlers does not affect their incredible manoeuvrability thanks to the minimum front boom and rear overhang. Simple and safe movements in tight spaces are its characteristic features.



STEERING METHODS

FRONT:
option recommended for
transfers.

CONCENTRIC:
guarantees a narrower
manoeuvring radius.

CRAB:
sideways movement for
approaches in tight spaces.

HYDRAULIC POWER

The hydraulic component is the real strength of this telehandler. Faresin Industries sought to oversize it to guarantee versatility of use, rapid work cycles, and fluid and precise movements. The hydraulic oil circuit adopts the same design logic to provide modular solutions for all uses, always with a view to optimising performance and minimising fuel consumption. There are two possible solutions with circuits starting from a flow rate of 95 l/min up to 150 l/min. The standard solution is with gear pump, or most performing solution with variable displacement piston pump, in load sensing.



QUICK COUPLING

It only takes a few seconds to switch tools thanks to the Faresin system allowing fast replacement in any work conditions.



CONFIGURABLE FLUIDITY

The high-performance flow-sharing distributors guarantee excellent multifunctionality, and thanks to their electronic management, the FS Joystick can be programmed for simultaneous control of multiple boom movements.

MORE EFFICIENCY

A strategic valve improves the efficiency of the hydraulic system and reduces fuel consumption. The Ecofast valve fluidifies and speeds up boom movements, even at low speed, allowing significant fuel savings.

AN EXTRA ECOFAST

Efficiency is the core of the FS project. Ecofast-E, which is electronically managed, also adds electronic load compensation, thus improving work safety and guaranteeing best control of the vehicle.

FULL ELECTRIC

Faresin FULL ELECTRIC is a line-up launched in 2018 with the unveiling of the first fully electric telehandler. FULL ELECTRIC machines are technological jewels, designed and industrialized by Faresin Industries, that embody the concept of effective sustainability: respect for the environment that does not sacrifice profitability and performance

The zero CO2 emissions allow their use even in closed environments, such as warehouses, logistics areas, agricultural activities, improving the level of comfort and safety in the working environment. The reduced noise level allows it to operate in environments and workplaces, where the use of endothermic engines is not recommended.

The Full Electric telehandler can be used in any working condition thanks to its maneuverability and its 4-wheel steering with all-wheel drive.

IDEAL FOR ECO-FRIENDLY INTERVENTIONS

Ideal for rental service for jobs that require environmental impact assessment and sustainability.

FIELDS OF USE

The Faresin electric telehandler is suitable for any type of application where the use of a combustion engine would be limited.

BUILDING AND SHIPBUILDING

- Historical centres
- Logistics
- Indoors (Fairs, events)
- Rental

SILENT AND EFFECTIVE

The same performance as a conventional telescopic handler without the noise of a combustion engine.

OPERATING COSTS -60%

The greater investment in the purchase phase is amortized on average after about 2 years of work.

CHEAP

Simple and cheap maintenance like that of an electric motor.

LITHIUM
BATTERY

0
EMISSION

NOISE
REDUCED





SUSTAINABLE FORCE

The chassis, entirely built by FARESIN, is compact and sturdy and can cope with all working conditions.

The FULL ELECTRIC is compatible with Euro and Faresin couplings and with a wide range of accessories for industrial, construction or agricultural use (forks, buckets, lifting-jibs).

In addition, the floating arm allows you to follow the ground perfectly when using sweepers or blades.

The transmission with regenerative braking keep the charging management efficient even during transfers inside the site.

The powerful LED work lights allow to operate even in non-illuminated areas.

GREEN VALUE

A 60% reduction in operating costs, no maintenance required for the diesel engine, and compliance with noise and exhaust gas pollution standards.

With its sustainable and silent power, it can operate freely on all urban sites and in all work areas previously excluded: closed places, environments with a high concentration of people, stations and airport areas, historical centres, greenhouses.



FULL ELECTRIC 6.26

Swift, silent and sustainable. 6.26 Full Electric Faresin is suitable for any type of use thanks to its lifting capacity of 2,6 tons and a maximum height of 6 meters. Twin to its endothermic engine version, it was designed to be the uncompromisingly ecological alternative.

It is the first Full Electric telehandler to be mass-produced globally according to unrivalled build quality standards.

TOTAL POWER

The centerpiece is the 80 V and 300, 400 or 560 Ah lithium battery kit that powers two electric motors, 30 kW for transmission and 18 kW for services. Power is delivered only when required, avoiding waste of energy and further extending the battery life.

4 TYPES OF CHARGING

Take advantage of the Fast charger and shorten the charging time during the work cycle. Use classic charging overnight. Standard onboard charger located inside the machine.

Four charging systems available: integrated in 7.5 hours, fast integrated 110 A in 3 hours, external 80 A within 5 hours and Fast 200 A to charge within 2 hours.



FULL ELECTRIC 14.42 - 17.40 - 17.45

A range created for great heights, with a three-section boom for a maximum lifting height of 17 meters and a maximum load capacity of 4.5 tons. Front stabilizers and tilt correction system ensure better performance and greater stability when lifting at high heights on any type of terrain.

Its centerpiece is the 45 kW/h, 435 V high-voltage lithium-ion battery that powers two electric motors, 51 kW for transmission and 23 kW for services. Power is delivered only when required, avoiding waste of energy and further extending battery life.

Thanks to this extraordinary power, the performance of the new Big Range Full Electric is in no way inferior to that of the endothermic engine versions. In fact, the optimized management of the transmission allows a peak traction force of 44.3 kN and the maximum speed is 25 km/h, managed by a two-speed gearbox.

UNIVERSAL CHARGE

Battery charging has never been easier. The onboard system allows batteries to be recharged with maximum flexibility, thanks to a single plug-in interface on the machine and a free choice of power supply: 220V single-phase, 400V three-phase and fast charging station.

SAFE AND PRECISE HANDLING

The hydraulic system is the real muscle of the telehandler. In this new electric range, an intelligent and powerful hydraulic system has been developed that allows for a flow rate of 120 l/min and a maximum pressure of 250 bar.

The variable displacement pump and the proportional electro-hydraulic Flow Sharing distributor guarantee significant energy savings, simultaneous movement and precise control.



QUEEN CAB: COMFORT, VISIBILITY AND ERGONOMICS



ERGONOMICS AND VISIBILITY

Queen Cab is designed to offer the best in ergonomics and visibility. The cab is equipped with an ergonomic seat with adjustable armrests and steering wheel to maximize operational efficiency. The new control panel allows everything to be kept under control while the new multi-function joystick ensures the millimetre precision of boom movements.



VENTILATION SYSTEM

An air conditioning, heating and ventilation system designed to work perfectly 365 days of the year. Easy regulation to find the right temperature for your working needs, in all conditions.

ELECTRO-PROPORTIONAL MECHANICAL JOYSTICK

- Mechanical proportional hydraulic system
- Ergonomic wrist rest
- Multifunctional
- Integrated FNR control
- Mechanical / proportional distributor
- Mechanically controlled lifting and slewing movements
- Electro-proportional control of auxiliaries and extension movements
- Gear service pump

ELECTRO-PROPORTIONAL HYDRAULIC JOYSTICK

- Proportional hydraulic system
- Ergonomic wrist rest
- Multifunctional
- Integrated FNR control
- Flow sharing distributor, hydraulic / proportional
- Load Sensing system
- Proportional hydraulic control of lifting and slewing movements
- Electro-proportional control of auxiliaries and extension movements
- Variable displacement load sensing piston service pump

EVERYTHING UNDER CONTROL

Dashboard with colour LCD multi-function intuitive display. The immediate viewing of all parameters allows the operator to identify operating needs in real time. The operator can rely on faster and more efficient service and maintenance management.



QUEEN CAB: COMFORT, VISIBILITY AND ERGONOMICS



The driver's cab of a telescopic handler is the operator's workstation for many hours a day. For this reason, Faresin is committed to the design and development of increasingly better solutions in terms of comfort, visibility and safety (ROPS, FOPS and ANSI certified cab).

ERGONOMICS AND VISIBILITY

Queen Cab is designed to offer the best in ergonomics and visibility. The cab is equipped with an ergonomic seat with adjustable armrests and steering wheel to maximize operational efficiency. The new control panel allows everything to be kept under control while the new multi-function joystick ensures the millimetre precision of boom movements.

EVERYTHING UNDER CONTROL

Dashboard with colour LCD multi-function intuitive display. The immediate viewing of all parameters allows the operator to identify operating needs in real time. The operator can rely on faster and more efficient service and maintenance management.

VENTILATION SYSTEM

An air conditioning, heating and ventilation system designed to work perfectly 365 days of the year. Easy regulation to find the right temperature for your working needs, in all conditions.





ELETTRO-PROPORTIONAL HYDRAULIC JOYSTICK

Electro-proportional hydraulic multi-function joystick available standard in versions HLS:

- ⊕ Proportional hydraulic system
- ⊕ Ergonomic wrist rest
- ⊕ Multifunctional
- ⊕ Integrated FNR control
- ⊕ Flow sharing distributor, hydraulic / proportional
- ⊕ Load Sensing system
- ⊕ Proportional hydraulic control of lifting and slewing movements
- ⊕ Electro-proportional control of auxiliaries and extension movements
- ⊕ Variable displacement load sensing piston service pump (152-180 l/min)



ELECTRO-PROPORTIONAL MECHANICAL JOYSTICK

Standard joystick for CLASSIC versions:

- ⊕ Mechanical proportional hydraulic system
- ⊕ Ergonomic wrist rest
- ⊕ Multifunctional
- ⊕ Integrated FNR control
- ⊕ Mechanical / proportional distributor
- ⊕ Mechanically controlled lifting and slewing movements
- ⊕ Electro-proportional control of auxiliaries and extension movements
- ⊕ Gear service pump (80-120 l/min)



STANDARD FIT-OUT

- ⊕ Document pockets
- ⊕ Bottle holder
- ⊕ Flashing light
- ⊕ Door with split openable glass
- ⊕ Heating and ventilation

MAIN OPTIONS

- ⊕ Front safety grill
- ⊕ Front and rear LED work lights with high lighting capacity
- ⊕ Upper rear wiper
- ⊕ Pneumatic suspension seat
- ⊕ Air conditioning



STAGE V ENGINES: POWER AND RELIABILITY



Faresin telehandlers are equipped with new Yanmar (51.7 kW) and Deutz (55.4, 74.4 and 100 kW) engines compliant with Stage V regulations capable of ensuring excellent power and reduced fuel consumption, on top of the best exploitation of the torque level which maximizes efficiency and durability. The longitudinal arrangement of the engine allows a fast accessibility for maintenance and gives the machine an optimal operational stability.

STAGE V ENGINES

Post-treatment of exhaust gases with DOC and DPF systems for all powers. The 74.4 and 100 kW versions also use the SCR system with AdBlue.

AIR FILTER

The air filter is equipped with a dust ejector system and a cyclone pre-filter, which significantly reduce maintenance work, guaranteeing maximum efficiency of the diesel engine.

ENGINE HOOD

Hood specifically designed to facilitate the best possible air flow.

CLEAN AND EFFICIENT

Optional reversible fan, manual or automatic operated. Positioned inside the engine compartment it keeps the radiating surfaces cleaned even in tough working conditions with extreme high temperatures.

The angle of inclination of the blades is variable according to the operating temperature in order to keep low power absorption and fuel consumption.

RADIATING SURFACE

Large radiating surface designed to guarantee maximum engine efficiency in the most heavy use and at the highest temperatures.



TRANSMISSIONS: FULL CONTROL AND RELIABILITY

CLASSIC

⊕ Single speed hydrostatic transmission, allowing a speed from 0-30 km/h; for easy manoeuvring with materials in the work area.

⊕ Hydrostatic transmission with 2-speed mechanical gearbox, allowing a speed of up to 40 km/h and different speed ranges for all types of work.



DRIVE

Maximum transmission performance.



ECO

Reduction of consumption in long transfers for the Middle, Heavy Duty and Big ranges.



HANDLING

Speed limited to 15 km / h and softer accelerator response curve for handling operations in the Heavy Duty and Big ranges.



HLS

Hydrostatic transmission with 2-speed mechanical gearbox, which allows a speed of 40 km/h and the possibility to choose the right speed for each type of work and to use large buckets.



DRIVE

Maximum transmission performance up to 40 km/h.



ECO

Reduction of consumption during transfers up to 40 km/h.



HANDLING

Speed limited to 15 km/h and softer accelerator response curve for handling operations, available for the Heavy Duty range.



CREEPER

Driving mode which makes it possible to have engine rpm independent from the vehicle velocity.



VPSe

VPSe is a continuously variable electronic transmission resulting from cooperation with Bosch Rexroth and combines two hydrostatic motors with a CVT automatic transmission.



DRIVE

Maximum transmission power up to 40 km/h



ECO

Eco-consumption reduction for long transfers up to 40 km/h



HANDLING

Speed limit 15 km/h



CREEPER

Driving mode that allows to separate speed of the diesel engine from the speed of the machine.

4-DRIVING WHEELS+ 3 STEERING SYSTEMS

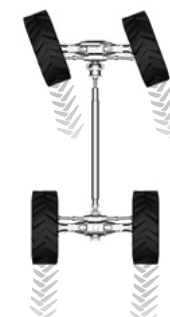

FRONT



CONCENTRIC



CRAB

INTELLIGENT HYDRAULICS

The hydraulic system designed by Faresin allows for maximum performance in different uses starting from the standard versions up to the top of the range. The intelligent systems developed, allow a significant reduction in cycle times and consequent reduction in consumption and costs.

INCHING MODE

The Inching function integrated in the brake pedal, standard on the whole range, allows the management and control of the forward speed in the most delicate handling operations.

REGENERATING VALVE UP HILL

The Heavy Duty range in versions with LS system (in HLS configuration) uses regenerative system technology.

This technology regenerates the oil emerging from the lifting cylinder while the boom is rising, adding it to the oil in circulation in the pump.

This process significantly reduces the boom lifting time in all operating conditions, especially at low diesel engine speeds and substantially reduces fuel consumption and cycle times (Tc) by up to 60% with respect to machines not equipped with this technology.



EXTRAORDINARY STRENGTH

The configuration of the monoblock frame ensures a low barycentre, thus offering increased stability. Its modular structure offers the machine high-level resistance to torsion in all conditions.

ROBUST FRAME MADE IN STEEL S355

FULLY WELDED BY ROBOTIC SYSTEMS TO ENSURE THE HIGHEST QUALITY

DURABILITY EVEN IN THE MOST EXTREME WORK CONDITIONS

AXLES

- ⊕ 45% limited slip type differential on front axle
- ⊕ OPEN type differential on rear axle
- ⊕ Internal disk brakes in oil bath for longer life
- ⊕ SAHR (Spring-Applied, Hydraulic-Release) emergency brakes and parking with hydraulic negative actuation
- ⊕ Side leveling that ensures maximum lifting and safety capacity on all types of terrain. Heavy Duty and Big Range std
- ⊕ Possibility of locking the rear axle to increase stability and bearing capacity on the wheels, optional on the Big Range

LIFTING HEIGHTS FOR EACH NEED

The telescopic boom made in steel S420 is hinged to the chassis in the low position. For maximum visibility during loading operations and better weight distribution. Models with one or more extensions allow to reach heights up to 17 meters.

- ⊕ Reinforcement plates in the points most subject to stress
- ⊕ Boom with up to 3 telescopic sections
- ⊕ Durability even in the most extreme work conditions
- ⊕ The boom suspension (optional) increases comfort and safety during road transfers with loads.

EASY MAINTENANCE

Routine maintenance on components are mandatory in order to maintain machine performance and reliability unaltered over time. The simplicity of execution and accessibility of components are synonymous with efficiency and savings.

CENTRALISED LUBRICATION

The centralised greasing system (optional) allows the main operating points to be lubricated every time the machine is switched on.

EXTENSION DRIVE SYSTEM

Two types available: a chain type for versions with 2 or more extensions and a piston type for the single extension version.

STRENGTH BOOM

Strenght boom, in steel, welded by robotised systems.

SWING

155° tilting for small range: the highest of its category.

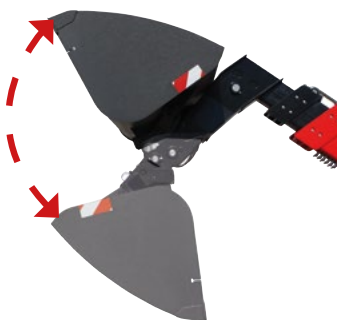

DATA SHEET





SERIE FS COMPACT

7.32C - 9.32C

MODELS		7.32C	9.32C
DIMENSIONS			
[A] Height	mm	2.250	2.250
[B] Width	mm	2.100	2.100
[C] Track	mm	1.670	1.670
[D] Ground clearance	mm	330	330
[E] Front overhang	mm	1.075	1.075
[F] Pitch	mm	2.950	2.950
[G] Rear overhang	mm	640	640
[H] Length without tow hook	mm	4.670	4.670
[I] Length with tow hook	mm	4.820	4.820
[L] Cab width	mm	960	960
HEIGHT MODEL LC (LOW CAB)	mm	2060	2060
WEIGHT			
CLASSIC 55	kg	6.350	6.750
CLASSIC 75	kg	6.400	6.800
DYNAMIC 85	kg	6.400	6.900
PERFORMANCE 85	kg	6.550	7.000
EXCELLENCE 85	kg	6.600	7.000
DETAILS			
Number of retracting sections	nr	1	2
Max flow rate	kg	3.200	3.200
Max lifting height	m	7,1	9,0
Horizontal max outreach	m	3,6	5,9
Outreach at max height	m	0,3	1,3
Swinging angle	°	155	155
TANK CAPACITY			
Hydraulic oil tank	l	120	120
Diesel tank	l	120	120

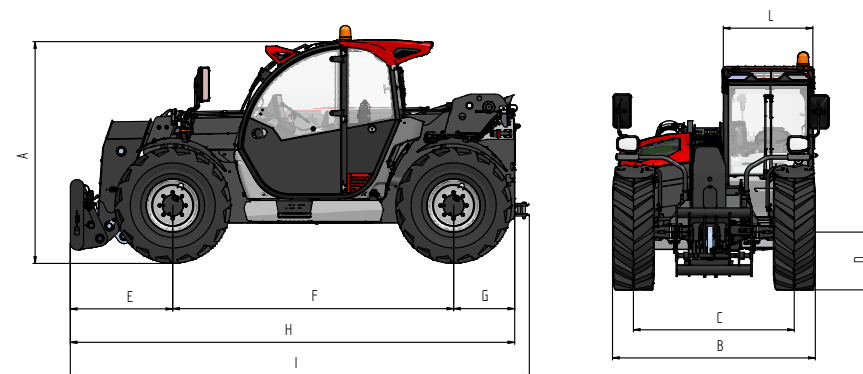

NOTE: Dimensions defined on Dynamic version with 20" wheels

INSTALLATIONS	CLASSIC 55	CLASSIC 75	DYNAMIC 85	PERFORMANCE 85	EXCELLENCE 85
TRANSMISSION					
Hydrostatic	single gear	single gear	single gear	2 mechanical gears	2 mechanical gears
Speed	km/h	30	30	30	40
ENGINE					
Manufactured	Deutz	Deutz	Deutz	Deutz	Deutz
Power	kW/hp	55,4/75	75/102	85/115	85/115
Post-treatment system	DOC + DPF	DOC/DPF + SCR	DOC/DPF + SCR	DOC/DPF + SCR	DOC/DPF + SCR
Pulling force	daN	4.330	4.330	4.330	7.000
HYDRAULICS					
Pump type	gears	gears	gears	LS piston	LS piston
Distributor	flow sharing	flow sharing	flow sharing	flow sharing	flow sharing
Hydraulic flow-rate	l/bar	100/250	100/250	120/250	150/250
TYRES					
400/70 20	●	●	●	○	○
405/70 24	○	○	○	●	●
Steering radius	m	3,8	3,8	3,8	3,8
VARIOUS					
Joystick	electro-hydraulic proportional	electro-hydraulic proportional	electro-hydraulic proportional	electro-hydraulic proportional	CAN-BUS electro proportional
Quick coupling	○	○	○	○	●
Rear hydraulic connection	○	○	○	●	●
LED front lights	○	○	○	○	●
LED rear lights	●	●	●	●	●
LED front and rear work lights	○	○	○	●	●
Trailer lights rear socket	○	○	●	●	●
Fixed tow hook 12 t	○	○	●	●	●
Engine water preheating	○	○	○	○	○
Air conditioning	○	○	○	○	●
Ecofast Valve	/	/	/	●	●
Floating boom	○	○	○	○	●
Boom suspension	○	○	○	○	○
Manual 6-way diverter valve	○	○	○	○	●
BES (Boom Electric Socket)	○	○	○	○	○
Creeper	●	●	●	●	●
Constant front flow	●	●	●	●	●
Bucket mode	●	●	●	●	●
Radiator fan	proportional	proportional	proportional	proportional + inversion	proportional + inversion

● Standard ○ Optional - Unavailable

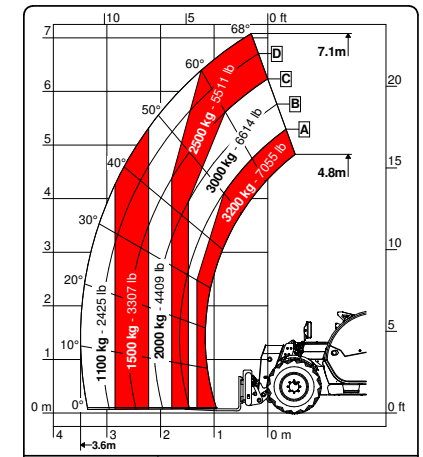

7.32C

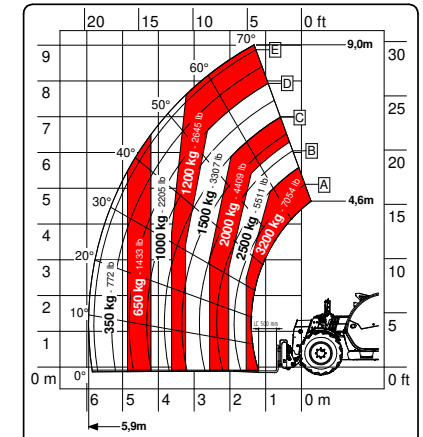

9.32C

SERIE FS MIDDLE

7.35 - 7.45 - 8.40 - 10.40

MODELS		7.35	7.45	8.40	10.40
DIMENSIONS					
[A] Height	mm	2450	2450	2450	2450
[B] Width	mm	2310	2310	2310	2310
[C] Track	mm	1862	1862	1862	1862
[D] Ground clearance	mm	350	350	350	350
[E] Front overhang	mm	1007	1007	1425	1390
[F] Pitch	mm	2950	2950	2950	2950
[G] Rear overhang	mm	804	804	804	804
[H] Length without tow hook	mm	4761	4761	5179	5144
[I] Length with tow hook	mm	4922	4922	5340	5305
[L] Cab width	mm	960	960	960	960
DETAILS					
Number of retracting sections	nr	1	1	1	2
Max flow rate	kg	3500	4500	4000	4000
Max lifting height	m	7,1	7,1	8	9,8
Horizontal max outreach	m	3,6	3,6	4,5	6,5
Outreach at max height	m	0,2	0,2	0,45	1,2
Swinging angle	°	144	144	144	144
TANK CAPACITY					
Hydraulic oil tank	l	120	120	120	120
Diesel tank	l	120	120	120	120

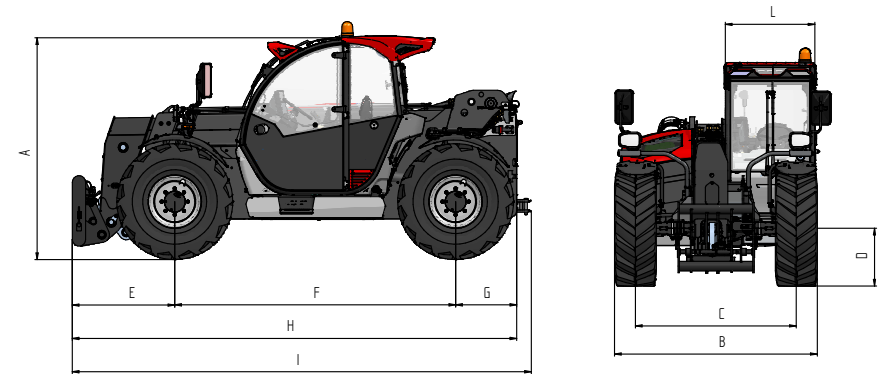

NOTE: Dimensions defined on Dynamic version with 20" wheels

INSTALLATIONS	CLASSIC 55	CLASSIC 75	DYNAMIC 85	PERFORMANCE 85	EXCELLENCE 85	EXCELLENCE VARIO 100
TRANSMISSION						
Hydrostatic	single gear	single gear	single gear	2 mechanical gears	2 mechanical gears	continuous variation
Speed	km/h	30	30	30	40	40
ENGINE						
Manufactured	Deutz	Deutz	Deutz	Deutz	Deutz	Deutz
Power	kW/hp	55,4/75	75/102	85/115	85/115	100/136
Post-treatment system	DOC + DPF	DOC/DPF + SCR	DOC/DPF + SCR	DOC + DPF + SCR	DOC + DPF + SCR	DOC + DPF + SCR
Pulling force	daN	4.330	4.330	4.330	5.890	5.890
HYDRAULICS						
Pump type	gears	gears	gears	pistons LS	pistons LS	pistons LS
Distributor	flow sharing	flow sharing	flow sharing	flow sharing	flow sharing	flow sharing
Hydraulic flow-rate	l/bar	100/250	100/250	120/250	150/250	170/250
WHEELS						
400/70 20	●	●	●	○	○	○
405/70 24	○	○	○	●	●	●
Steering radius	m	3,8	3,8	3,8	4,15	4,15
VARIOUS						
Joystick	electro-hydraulic proportional	electro-hydraulic proportional	electro-hydraulic proportional	electro-hydraulic proportional	CAN-BUS electro proportional	CAN-BUS electro proportional
Quick coupling	○	○	○	○	●	●
Rear hydraulic connection	○	○	○	●	●	●
LED front lights	○	○	○	○	●	●
LED rear lights	●	●	●	●	●	●
LED front and rear work lights	○	○	○	●	●	●
Trailer lights rear socket	○	○	●	●	●	●
Fixed tow hook 12 t	○	○	●	●	●	●
Engine water preheating	○	○	○	○	○	○
Air conditioning	○	○	○	○	●	●
Ecofast Valve	/	/	/	●	●	●
Floating boom	○	○	○	○	●	●
Boom suspension	○	○	○	○	○	○
Manual 6-way diverter valve	○	○	○	○	●	●
BES (Boom Electric Socket)	○	○	○	○	○	○
Creeper	●	●	●	●	●	●
Constant front flow	●	●	●	●	●	●
Bucket mode	●	●	●	●	●	●
Radiator fan	proportional	proportional	proportional	proportional + inversion	proportional + inversion	proportional + inversion

● Standard ○ Optional - Unavailable

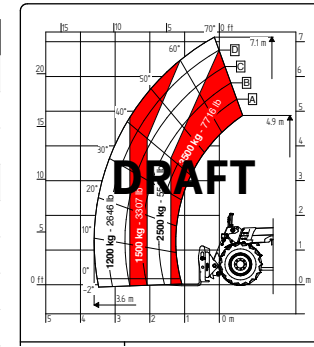

7.35

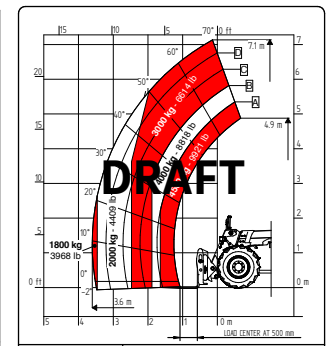

7.45

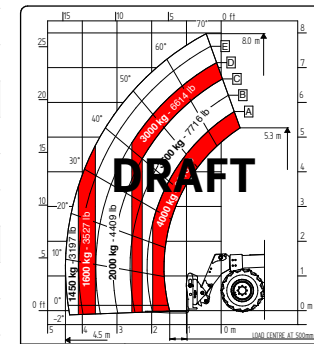

8.40

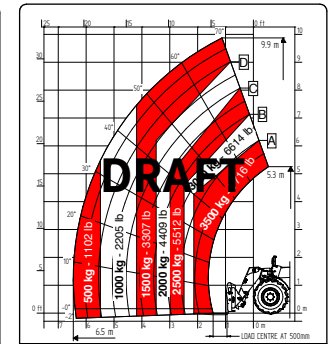

10.40

FULL ELECTRIC

6.26

MODELS		6.26
DIMENSIONS		
[A] Height	mm	1935
[B] Width	mm	1890
[C] Gauge	mm	1550
[D] Ground clearance	mm	220
[E] Front overhang	mm	990
[F] Pitch	mm	2525
[G] Rear overhang	mm	520
[H] Length	mm	4035
[I] Cabin width	mm	960
DETAILS		
Number of extracting sections	nr	1
Max capacity	kg	2600
Max lifting height	m	5,9
Max horizontal boom extension	m	3,2
Boom extension at max height	m	0,3
Swinging Angle	°	155
Weight	kg	4800
TANK CAPACITY		
Hydraulic oil tank	l	80
CONNECTION FOR EQUIPMENT		
FH		●
EURO		○

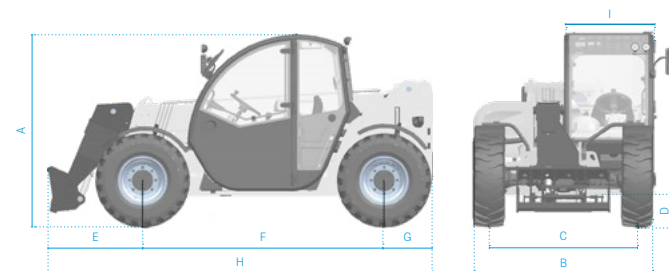

NOTES: Dimensions defined on model with 16" wheels

CONFIGURATIONS		FULL ELECTRIC
TRANSMISSION		
Transmission		electric
Speed	km/h	12
MOTOR		
Transmission S2	kW	30
Hydraulic services S3	kW	18
HYDRAULIC		
Pump type		gears pump
Hydraulic capacity	l/bar	80/230
TYRES		
12-16,5		●
12,5-18		○
435/50 19.5		○
Turning radius	m	3,25
OTHER		
Joystick		mechanical-electro proportional
Cabin		Queen Cab
Quick coupling		○
Front and rear LED lights		○
Floating boom		○
Boom suspension		○
Manual 6-way diverter		○
PEB (Boom Electric Socket)		○
Front constant flow		○
Bucket mode		●
SPECIAL FEATURES		
Air conditioning		○
Forward buzzer avas		○
Farmatics		FULL (2-5 years)

BATTERIES	24 kW/h (315 Ah)	32 kW/h (420 Ah)	43 kW/h (560 Ah)	
AUTONOMY STANDARD CYCLE INTENSIVE (eco mode)	UP TO 3 HOURS	UP TO 4 HOURS	UP TO 6 HOURS	
AUTONOMY STANDARD CYCLE NOT INTENSIVE (eco mode)	UP TO 6 HOURS	UP TO 8 HOURS	UP TO 11 HOURS	
CHARGERS				
STANDARD ON BOARD MONO PHASE CHARGER	0-80%	6 h	8 h 50 m	11 h 20 m
POWER INPUT 16 A 240 VAC				
POWER OUTPUT 35 A 80 VDC	0-100%	8 h 15 m	11 h 40 m	14 h 50 m
EXTERNAL THREE PHASES CHARGER 400V - 80A	0-80%	3 h 10 m	4 h 30 m	5 h 40 m
POWER INPUT 18 A 400 VAC				
POWER OUTPUT 80 A 80 VDC	0-100%	4 h 50 m	6 h 20 m	8 h
EXTERNAL THREE PHASES FAST CHARGER 400V - 200A	0-80%	1 h 10 m	1 h 40 m	2 h 10 m
POWER INPUT 43 A 400 VAC				
POWER OUTPUT 200 A 80 VDC	0-100%	2 h	2 h 45 m	3 h 40 m
ON BOARD FAST CHARGER	0-80%	2 h 20 m	3 h	3 h 50 m
POWER INPUT 16 A 400 VAC				
POWER OUTPUT 110 A 80 VDC	0-100%	3 h 20 m	4 h 30 m	5 h 40 m

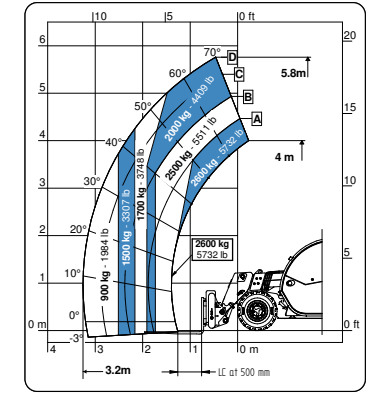

6.26

● Standard ○ Optional - Unavailable

FULL ELECTRIC

14.42 - 17.40 - 17.45

MODELS		14.42	17.40	17.45
DIMENSIONS				
[A] Height	mm	2500	2500	2560
[B] Width	mm	2331	2331	2360
[C] Gauge	mm	1862	1862	1832
[D] Ground clearance	mm	280	280	340
[E] Front overhang	mm	2180	2330	2330
[F] Pitch	mm	2950	2950	2950
[G] Rear overhang	mm	1240	1240	1240
[H] Width with stabilizers	mm	3418	3418	3418
[I] Length	mm	6370	6520	6520
[L] Cabin width	mm	960	960	960
DETAILS				
Number of extracting sections	nr	2	3	3
Max capacity	kg	4200	4000	4500
Max lifting height	m	13,6	16,4	16,4
Max horizontal boom extension	m	9,75	12,6	12,6
Boom extension at max height	m	1,6	2,5	2,5
Swinging Angle	°	144	144	144
TANK CAPACITY				
Hydraulic oil tank	l	150	150	150
CONNECTION FOR EQUIPMENT				
FH		●	●	●

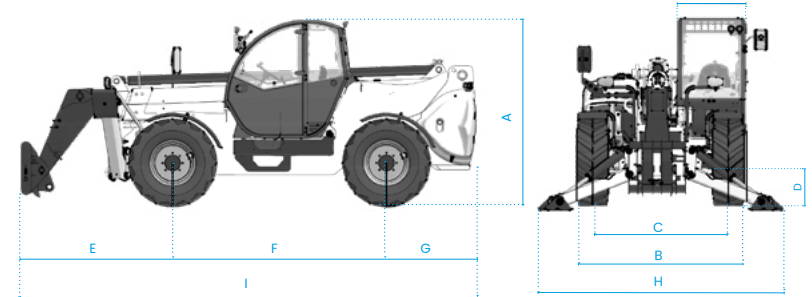

NOTES: Dimensions defined on model with 20" wheels

CONFIGURATIONS FULL ELECTRIC

TRANSMISSION

Transmission		electric
Speed	km/h	25

MOTOR

Transmission S2	kW	51
Hydraulic services S3	kW	23

HYDRAULIC

Pump type		gears pump
Hydraulic capacity	l/bar	120/250

TYRES

405/70 20		●
405/70 24		○
445/65 R22.5*		○
Turning radius	m	4,2

OTHER

Joystick		mechanical-electro proportional
Cabin		Queen Cab
Quick coupling		○
Front and rear LED lights		○
Floating boom		○
Boom suspension		○
Manual 6-way diverter		○
PEB (Boom Electric Socket)		○
Front constant flow		○
Bucket mode		●

SPECIAL FEATURES

Air conditioning		○
Forward buzzer avas		○
Farmatics		FULL (2-5 years)

* standard on 17.45

● Standard ○ Optional - Unavailable

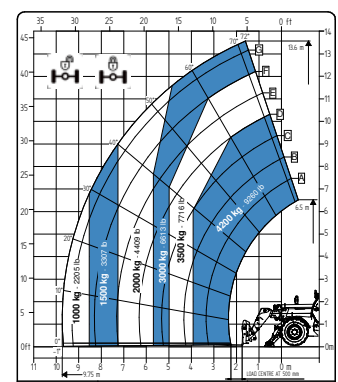

14.42

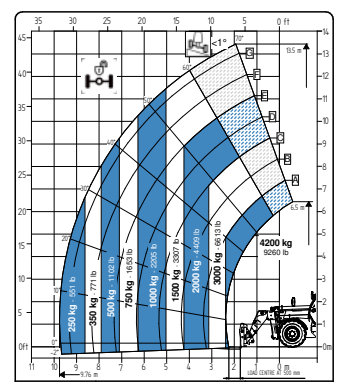

14.42

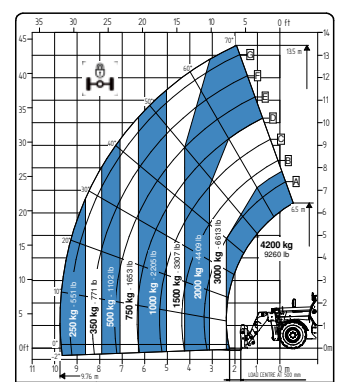

14.42

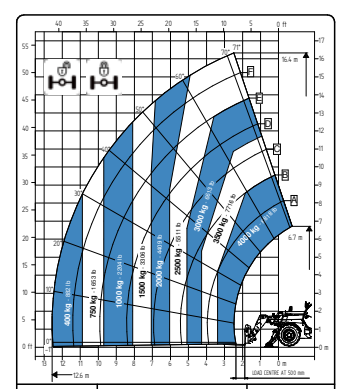

17.40

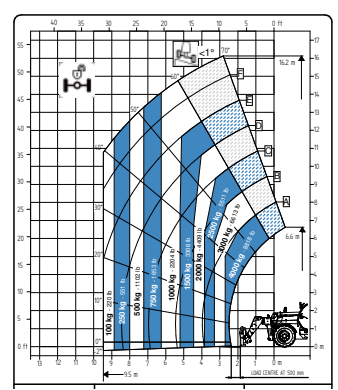

17.40

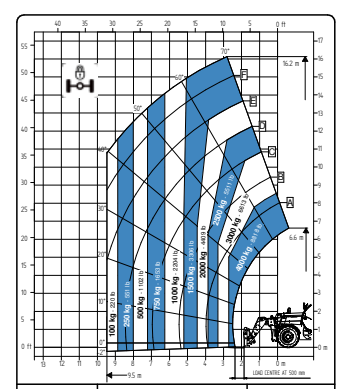

17.40

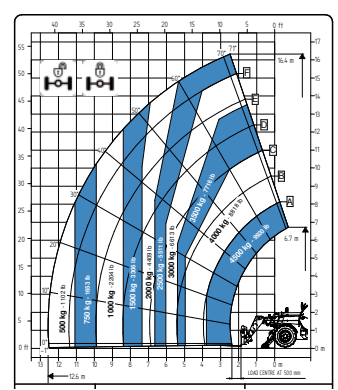

17.45

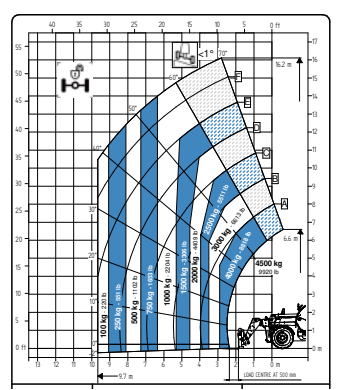

17.45

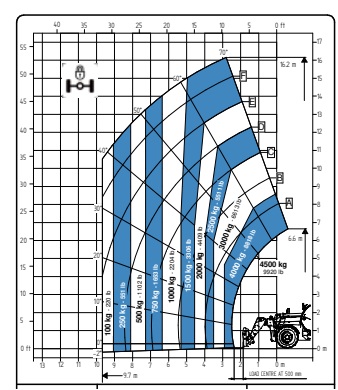

17.45

SMALL RANGE

6.26

MODELS		6.26
DIMENSIONS		
[A] Height	mm	1935
[B] Width	mm	1890
[C] Gauge	mm	1550
[D] Ground clearance	mm	220
[E] Front overhang	mm	990
[F] Pitch	mm	2525
[G] Rear overhang	mm	520
[H] Length	mm	4035
[I] Cabin width	mm	960
WEIGHT		
Classic 52	kg	4700
DETAILS		
Number of extracting sections	nr	1
Max capacity	kg	2600
Max lifting height	m	5,9
Max horizontal boom extension	m	3,2
Boom extension at max height	m	0,3
Swinging Angle	°	155
TANK CAPACITY		
Hydraulic oil tank	l	80
Diesel tank	l	70
CONNECTION FOR EQUIPMENT		
FH		●
EURO		○

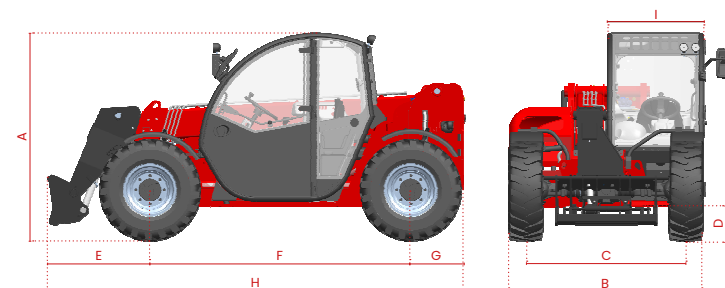

NOTES: Dimensions defined on model with 16" wheels

CONFIGURATION		CLASSIC 52
TRANSMISSION		
Hydrostatic		single gear
Speed	km/h	30
ENGINE STAGE V		
Builder		Yanmar
Power	kW/hp	51,7/69,3
Aftertreatment system		DOC + DPF
Drawbar pull	daN	3530
HYDRAULIC		
Pump type		gears pump
Hydraulic capacity	l/bar	80/230
TYRES		
12-16,5		●
12,5-18		○
435/50 19.5		○
Turning radius	m	3,25
OTHER		
Joystick		mechanical-electro proportional
Quick coupling		○
Electro-proportional double acting rear hydraulic connection		○
Front and rear LED lights		○
Rear trailer lights socket		○
6 t fixed tow hook		○
Engine water pre-heating		○
Air conditioning		○
Floating boom		○
Boom suspension		○
Manual 6-way diverter		○
PEB (Boom Electric Socket)		○
Creeper		○
Front constant flow		○
Pneumatic / hydraulic trailer brake		○
Bucket mode		●

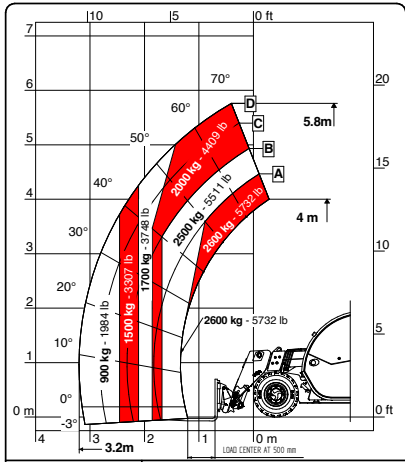

6.26

● Standard ○ Optional - Unavailable

HEAVY DUTY RANGE

9.60 - 9.70 - 10.65

MODELS		9.60	9.70	10.65
DIMENSIONS				
[A] Height	mm	2550	2550	2550
[B] Width	mm	2334	2334	2334
[C] Gauge	mm	1840	1840	1840
[D] Ground clearance	mm	410	410	410
[E] Front overhang	mm	1373	1373	1673
[F] Pitch	mm	2950	2950	2950
[G] Rear overhang	mm	1265	1265	1265
[H] Length without tow hitch	mm	5556	5556	5856
[I] Length with tow hitch	mm	5628	5628	5928
[L] Cabin width	mm	960	960	960
WEIGHT				
Classic 74	kg	10400	10700	11050
HLS 74	kg	10600	10900	11200
VPSe 100	kg	10750	11000	11250
DETAILS				
Number of extracting sections	nr	1	1	1
Max capacity	kg	6000	7000	6500
Max lifting height	m	8,8	8,8	9,5
Max horizontal boom extension	m	4,75	4,75	5,4
Boom extension at max height	m	0,2	0,2	0,45
Swinging Angle	°	149	149	149
TANK CAPACITY				
Hydraulic oil tank	l	150	150	150
Diesel tank	l	120	120	120
CONNECTION FOR EQUIPMENT				
FH HEAVY		●	●	●

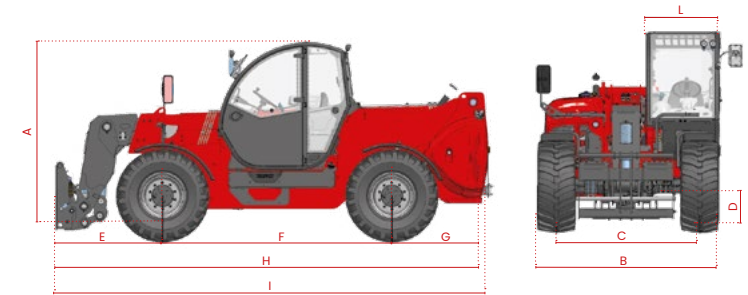

NOTES: Dimensions defined on model with 22" wheels

CONFIGURATION	CLASSIC 74	HLS 74	VPSe100
TRANSMISSION			
Hydrostatic	two mechanical gears	two mechanical gears	continuous variation
Speed	km/h	40	40
ENGINE TIER 4 FINAL			
Builder	Deutz	Deutz	Deutz
Power	kW/hp	74,4/101	74,4/101
Aftertreatment system	DOC + DPF + SCR	DOC + DPF + SCR	DOC + DPF + SCR
Drawbar pull	daN	8500	9000
HYDRAULIC			
Pump type	gears pump	LS piston pump	LS piston pump
Hydraulic capacity	l/bar	120/230	152/250
TYRES			
445/65 R22,5	●	●	●
Turning radius	m	4,5	4,5
OTHER			
Joystick	mechanical-electro proportional	hydraulic-electro proportional	hydraulic-electro proportional
Quick coupling	○	○	●
Electro-proportional double acting rear hydraulic connection	○	○	○
Front and rear LED lights	○	○	○
Rear trailer lights socket	○	●	●
6 t fixed tow hook	○	●	●
Engine water pre-heating	○	○	○
Air conditioning	○	○	●
Regeneration valve in ascent	-	●	●
Floating boom	○	○	○
Boom suspension	○	○	○
Manual 6-way diverter	○	○	○
PEB (Boom Electric Socket)	○	○	○
Creeper	○	●	●
Front constant flow	○	○	○
Bucket mode	●	●	●
Pneumatic / hydraulic trailer brake	○	○	○
Frame lateral levelling ±10°	●	●	●

● Standard ○ Optional - Unavailable

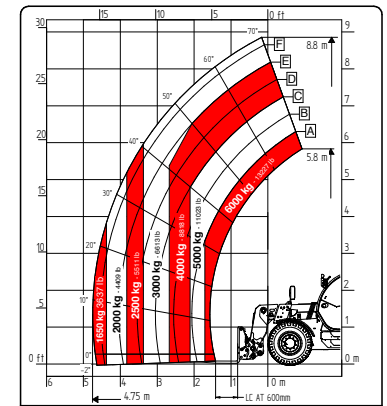

9.60

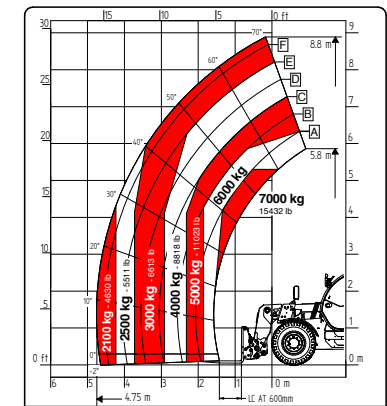

9.70

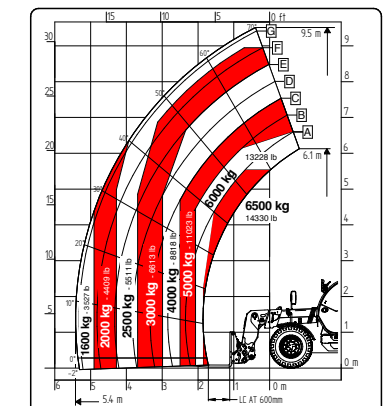

10.65

BIG RANGE

14.42 - 17.40 - 17.45

MODELS		14.42	17.40	17.45
DIMENSIONS				
[A] Height	mm	2500	2500	2560
[B] Width	mm	2331	2331	2360
[C] Gauge	mm	1862	1862	1832
[D] Ground clearance	mm	280	280	340
[E] Front overhang	mm	2180	2330	2330
[F] Pitch	mm	2950	2950	2950
[G] Rear overhang	mm	1240	1240	1240
[H] Width with stabilizers	mm	3418	3418	3418
[I] Length	mm	6370	6520	6520
[L] Cabin width	mm	960	960	960
WEIGHT				
Classic 55	kg	11000	11660	12080
Classic 74	kg	11110	11810	12150
DETAILS				
Number of extracting sections	nr	2	3	3
Max capacity	kg	4200	4000	4500
Max lifting height	m	13,6	16,4	16,4
Max horizontal boom extension	m	9,75	12,6	12,6
Boom extension at max height	m	1,6	2,5	2,5
Swinging Angle	°	144	144	144
TANK CAPACITY				
Hydraulic oil tank	l	150	150	150
Diesel tank	l	120	120	120
CONNECTION FOR EQUIPMENT				
FH		●	●	●
EURO		○	○	○

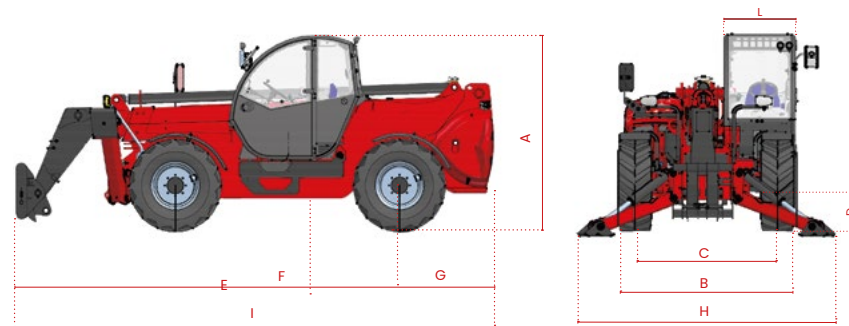

NOTES: Dimensions defined on model with 20" wheels

CONFIGURATION	CLASSIC 55	CLASSIC 74
TRANSMISSION		
Hydrostatic	single gear	single gear
Speed	km/h 25	30
ENGINE STAGE V		
Builder	Deutz	Deutz
Power	kW/hp 55,4/75,3	74,4/101
Aftertreatment system	DOC + DPF	DOC + DPF + SCR
Drawbar pull	daN 5000	5000
HYDRAULIC		
Pump type	gears pump	gears pump
Hydraulic capacity	l/bar 120/230	120/230
TYRES		
405/70 20	●	●
405/70 24	○	○
445/65 R22.5	○	○
Turning radius	m 4,2	4,2
OTHER		
Joystick	mechanical-electro proportional	mechanical-electro proportional
Quick coupling	○	○
Electro-proportional double acting rear hydraulic connection	○	○
Front and rear LED lights	○	○
Rear trailer lights socket	○	○
6 t fixed tow hook	○	○
Engine water pre-heating	○	○
Air conditioning	○	○
Floating boom	○	○
Boom suspension	○	○
Manual 6-way diverter	○	○
PEB (Boom Electric Socket)	○	○
Creeper	○	○
Front constant flow	○	○
Bucket mode	●	●
Pneumatic / hydraulic trailer brake	○	○
Frame lateral levelling ±10°	●	●
Front Stabilizers	●	●
Rear axle swing block	○	○

● Standard ○ Optional - Unavailable

* standard on 17.45

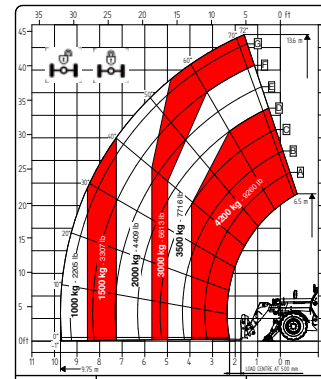

14.42

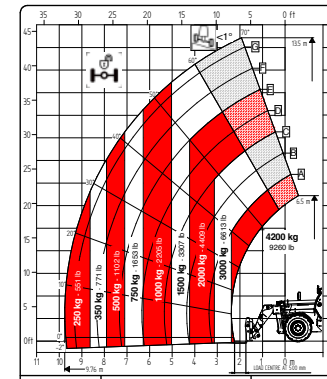

14.42

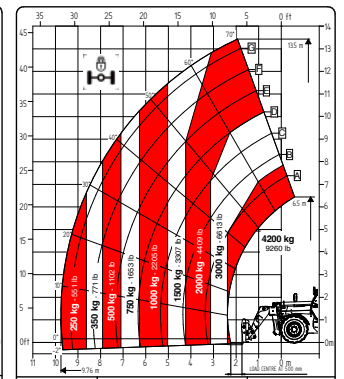

14.42

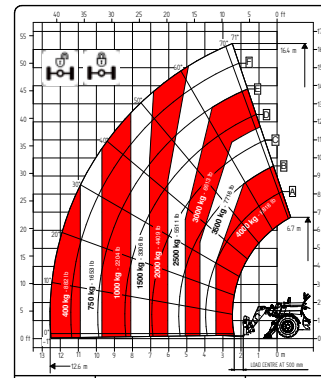

17.40

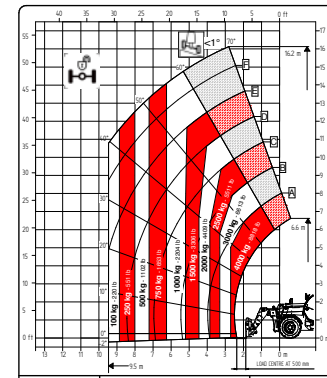

17.40

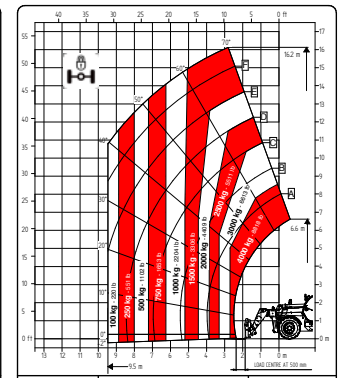

17.40

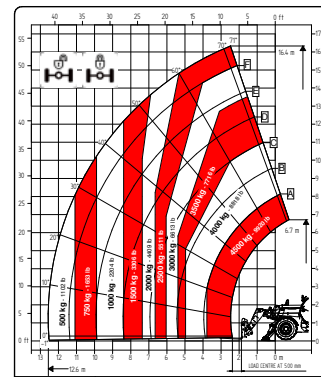

17.45

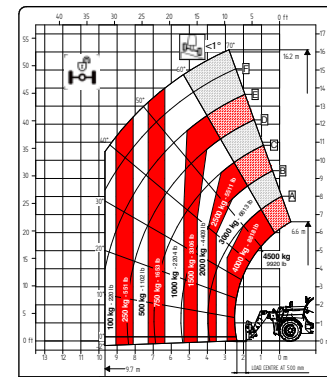

17.45

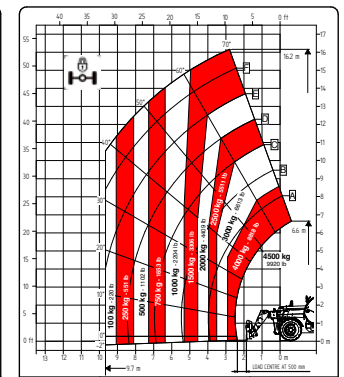

17.45

ACCESSORIES



MANURE FORK WITH GRAB



MANURE FORK WITHOUT GRAB



ROUND BALE GRAB LOG GRAB



FORK WITH 2 PIVOTING NEEDLES



FORK WITH 3 PIVOTING NEEDLES

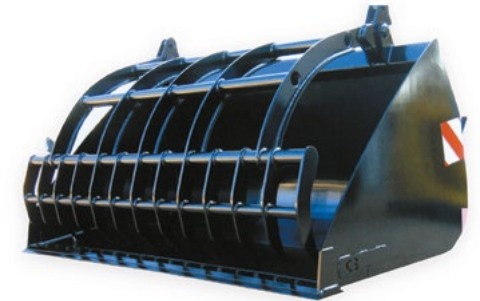

BUCKET WITH GRAB



PALLET FORKS



MULTI BALES GRAB



SILAGE CUTTER



LOG GRAB

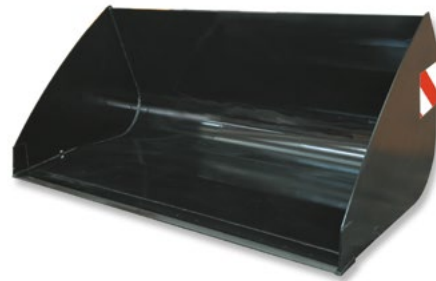

LIGHT MATERIAL BUCKET



BUCKET WITH TINES

FARMATICS CONNECTIVITY

Managing company machinery, exchanging information, optimising maintenance and preventively monitoring problems, will be the standards of the near future. All models in the FS range are ready for the upcoming integrations. Faresin recommends protecting the machine's value by strictly following the scheduled maintenance suggestions provided by the Manufacturer.

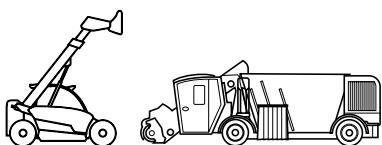
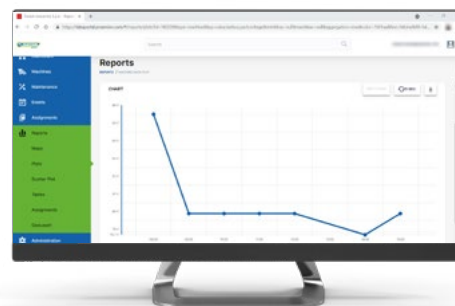
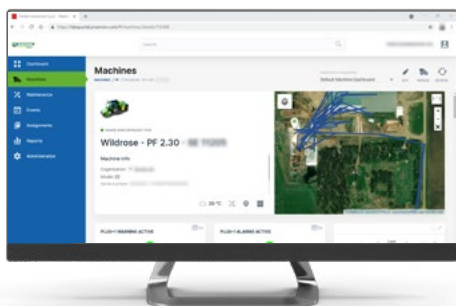
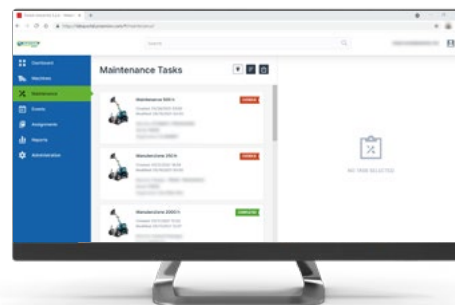
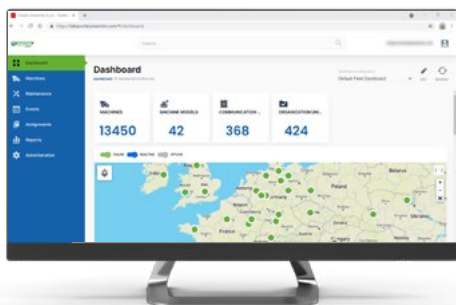

+

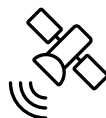

GPS

+



eSIM

+



CLOUD

+



PC, TABLET,
SMARTPHONE

FARMATICS

POWERED BY FARE SIN

WHY FARMATICS?

GEOLOCALISATION AND FLEET MANAGEMENT ✓

REMOTE SUPPORT ✓

CREATION OF DETAILED AND CUSTOMISED
GRAPHICS FOR ALL REGISTERED SIGNS ✓

PERFORMANCE AND
FUEL CONSUMPTION MONITORING ✓

MAINTENANCE PROGRAMMING
AND COST MANAGEMENT ✓



AFTER SALES

The telehandler is a machine produced by Faresin Industries for more than 20 years with results that have constantly been met with market appreciation. A story of constant growth, which has led the company to acquire important design and industrial skills. Moreover, advice was welcomed and client needs were heard to create a high-level services package for those who need to work productively every day.

24/365 SUPPORT SERVICE

Customer satisfaction means being able to solve the problem when it occurs, in the shortest possible time. Hence why the Faresin support service is active 24 hours a day, 365 days a year.

EXTENDED WARRANTY

To strengthen our proposal to the client, we offer a complete flexible Extended Warranty program with options to cover our products even up to 3 years or 5000 hours. The final result is of course a machine with better maintenance and a complete history of vehicle assistance, with positive returns when the time comes for its replacement. For companies, it guarantees known costs of ordinary and special maintenance.



[FARESINSHOP](#)



ORIGINAL SPARE PARTS

In order to provide after-sales support, Faresin has activated a series of tools to provide original spare parts, guaranteeing delivery throughout Europe within 24 hours of ordering. Faresin recommends using original spare parts to ensure the best performance of its machines.





**FARESIN INDUSTRIES SPA
HEADQUARTERS**

Via dell'Artigianato, 36
36042 Breganze (Vicenza),
Italy
Tel. + 39 0445 800300
faresin@faresin.com

**FARESIN DEUTSCHLAND
GMBH**

Steinach B.R. - an der
Frankenhöhe 1
91605 Gallmersgarten,
Germany
Tel. +49 9843 9802828
lager@faresin.de

**FARESIN DEUTSCHLAND
NORD GMBH**

Wissmannstr, 59
27755 Delmenhorst, Germany
Tel. +49 4221 800 989-0
info@faresin-nord.de

**FARESIN POLAND
SP. Z O.O.**

ul. Borowiacka 9
87-100 Toruń, Polska
Tel. +48 503 147 811
poland@faresin.com

**FARESIN INDUSTRIES
FRANCE**

2 Rue de l'Avenir 14460
Colombelles, France
Tel + 33 2 31 82 79 61
france@faresin.com



11.2022



FARESIN.COM

It brings to the attention of all potential customers, all recipients, and to the maximum extent possible, external interlocutors, that Faresin Industries S.p.A. adopts a general Disclaimer regarding the description of the technical and functional characteristics of its machineries, as well as the manner of their use, also with regard to their safety. The Disclaimer must be understood as having a general scope, and therefore Faresin Industries s.p.a. invites to know it, also by accessing the website: faresin.com